

Bladon—Thermal Bridging

The first designs for this site reflected Kingerlee Homes' progressive approach with a modern design. The Planners were supportive of this and recommended the initial contemporary scheme for approval but the Planning Committee however wanted the scheme to be 'more like Bladon', and were keen to mark the heritage of the site as a stone quarry for the adjoining Blenheim estate, and so the initial designs had to be significantly changed and then modified again. Planning restrictions on height meant the roof lines became complex as they were refined and the aesthetics and design constraints reduced the flexibility and potential for good, simple thermal design and resulted in an unwelcome level of complexity to the final design. Extra complexity leads to extra junctions and therefore lower performance.

The thermal design of the homes was based on a well insulated slab and 365mm Thermoplan single skin cellular insulation monolithic clay block walls with stone or render facing with U-value: $0.26 \text{ kWh/m}^2\text{k}$ (0.28) $y = 0.05$

The roof is slated over low timber content I-beam rafters, supported by timber trusses and steel purlins. I-beam timber joists also form the first floor. Warmcel recycled insulation is used throughout the roof and first floor.

Careful attention was given to selection and use of a complete build system design that reduced thermal bridging to a minimum. Construction details using ThermoPlan were calculated to an exceptionally low y -value = 0.024

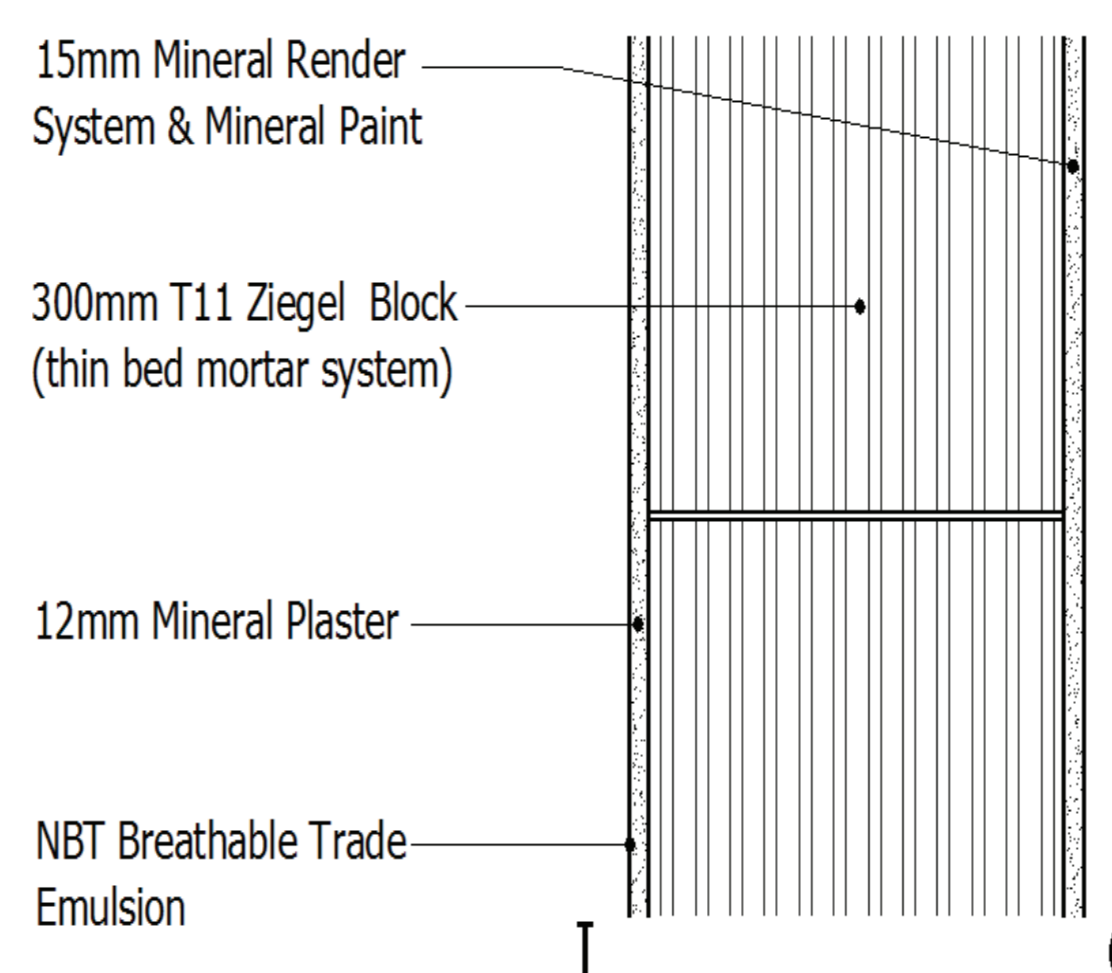

Geometric thermal bridges

The simple shape of the thermal envelope was compromised by the nature of the planning restrictions both on site lines, height and also aesthetics made junctions more complex. This together with a changing design, a structural engineer with no interest or knowledge in thermal design, led to a challenging build. Junctions and joins were given careful attention to make sure operatives understood they they should be thermally broken

Repeating thermal bridges

The well insulated slab – two slabs of 75mm polystyrene with offset joints and 50mm polystyrene edge insulation – all were checked before pour, and the Thermoplan single skin wall system prevented the most common form of repeating bridge – the wall tie.

Junctions with steels were carefully detailed and extra insulation around the joints - included – thermal breaks

The timber I beam rafters also reduce thermal bridging as the web reduces the flow of heat

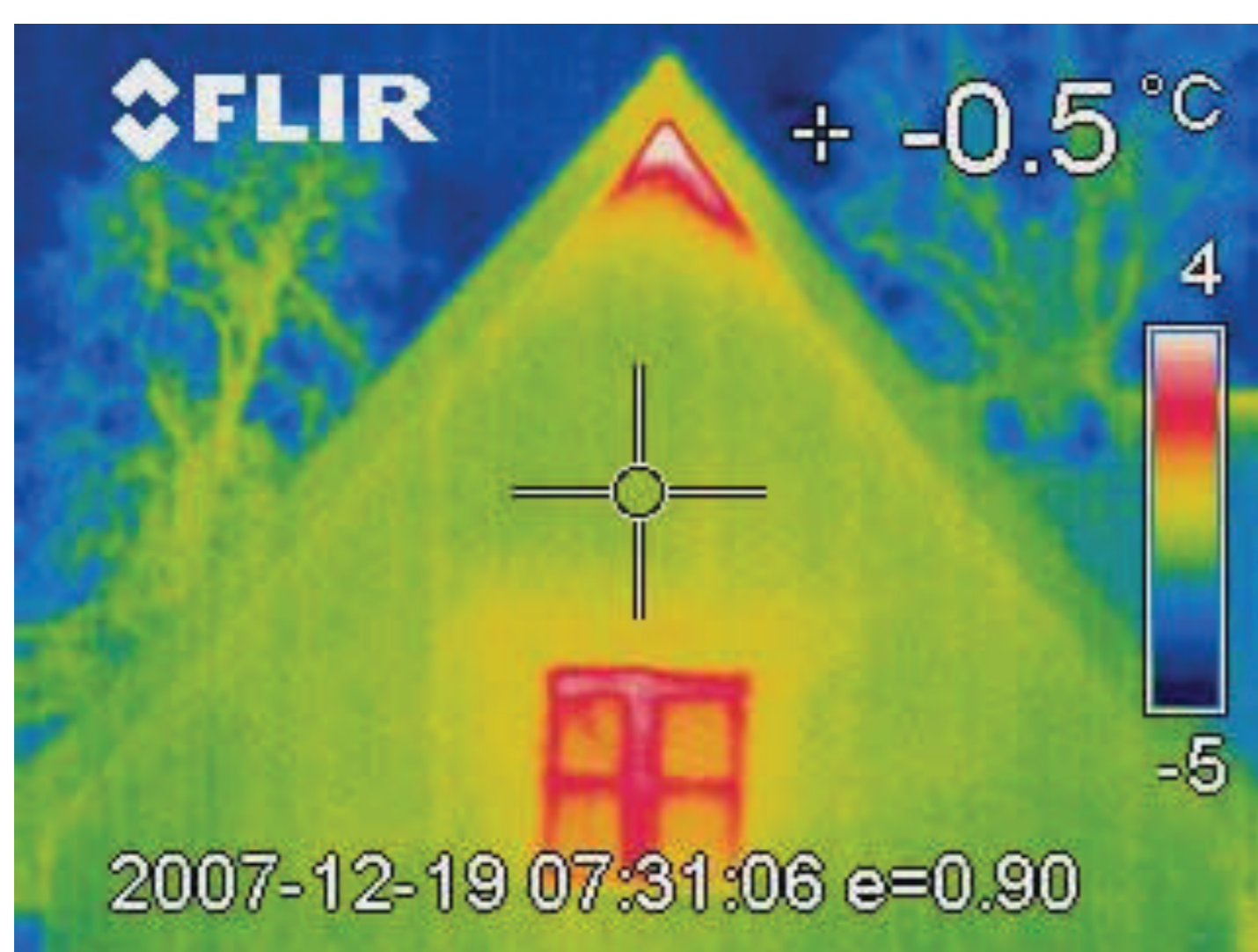

Non-repeating thermal bridges

Working with Peter Warm and NBT consult, an airtightness schedule and 37 point checklist was devised to make sure that all the following areas were checked

- Completion of radon barrier
- First plank of first floor
- First steel purlins
- Final membrane roof sealing

Also included on the check list was ensuring the lintels contained the insulation before casting and were cast, at First floor – fully filled bearing, insulated ends of I beams and careful attention to ends and sealing of steel purlins

Rules to assist in the avoidance of thermal bridging at Bladon

- Understand your subject
- Consider a build system or MMC with single skin wall – no additional insulation or wall ties
- Train design and construction staff
- Create a checklist for the development that defines the most likely points and stage in the construction process for loss of thermal performance
- Ensure that contractors take ownership and responsibility for thermal design on site.